

AIR IMPACT WRENCH

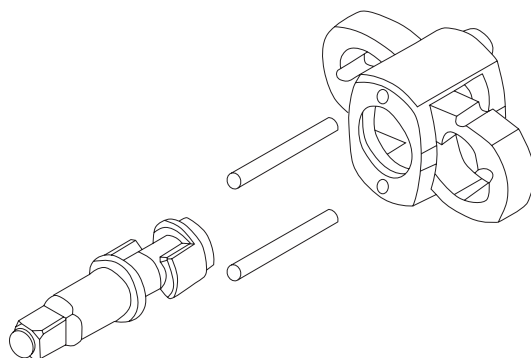

PRODUCT FEATURES

Compact size and low weight of wrench. Impact mechanism with a double hammer clutch. Left / right direction switch. 3 tightening torque positions and 3 loosening ones. Downward air inlet in the handle. Body made from aluminum, handle covered with rubber. Universal quick coupling 1/4".



1/2"	max 610 Nm	10000/min	6,2 bar	169 l/min	TWIN HAMMER	R/L	1,50kg LIGHT WEIGHT	125mm COMPACT SIZE	CE
------	------------------	-----------	------------	--------------	----------------	-----	---------------------------	--------------------------	----

CODE	SQUARE	MAX. TORQUE [NM]	
66370	1/2"	610	10