

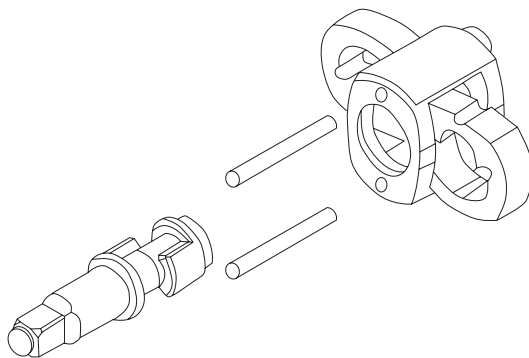

### PRODUCT FEATURES

Designed for professional use. Very high torque with a small-size spanner. Impact mechanism with a double hammer clutch. Left / right direction switch. 3 tightening torque positions and 3 loosening ones. Downward air inlet in the handle. Body made from aluminum, handle covered with rubber. Universal quick coupling 1/4".



1/2"
max 1356 Nm
n:9000/min
6,3 bar
144 l/min
TWIN HAMMER
R/L
1,80kg LIGHT WEIGHT
141mm COMPACT SIZE
CE

CODE	SQUARE	MAX. TORQUE [NM]	
66472	1/2"	1356	10

**PROLINE®**