

CARBIDE TIPPED CIRCULAR SAW FOR NON-FERROUS METALS CUTTING

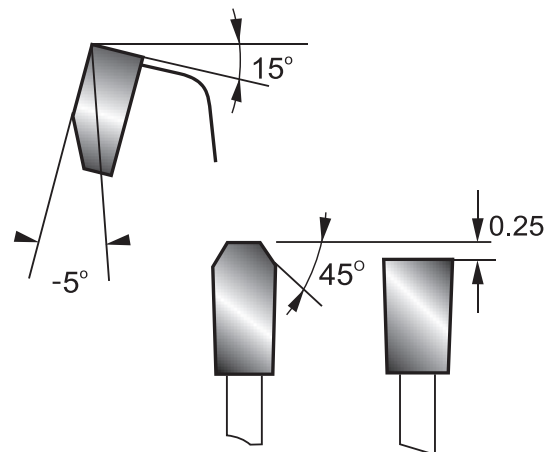

PRODUCT FEATURES

High-quality sintered carbide. Quenched and tempered disc. For cutting aluminum and its alloys. The saw is delivered with a ring reducing the diameter of the installation opening.



TCT

CODE	DIAMETER [MM]	BORE/ADAPTER	TEETH NUMBER	☒	📦
84720	200	30/20/16	100	x	25/50
84721	205	30/20/16	100	x	25/50
84722	210	30/20/16	100	x	25/50
84725	250	30/20/16	100	x	10/20